

Ideal for machine installation

Beautifully designed for heavy traffic

VS 5™ is a structural pavement consisting of square stones with shift protection on all sides and underneath. These shift protections provide stable conditions for both horizontal and vertical loads. VS 5™ stones come in a variety of colors and finishes to enhance its appearance.

- Suitable for very high traffic loads
- Reduces vertical and horizontal shifting
- Increased resistance to wash out of joint material between paving stones
- Smooth surface for wheelchair users

The ultimate in **pavement stability** and **appearance** for **heavy** and **constant** traffic.



Composition and Manufacture

VS 5™ is made from a no slump concrete mix. Has a compressive strength greater than 8000 psi, a maximum water absorption of 5% and will meet or exceed ASTM C-936 and freeze-thaw testing per section 8 of ASTM C-67.

Nominal Dimensions:

- Height/Thickness (without profiles) 3 1/8" (80 mm)
- Length (w/o spacer bars) 11 3/4" (296 mm)
- Width (w/o spacer bars) 11 3/4" (296 mm)
- Raster size: 300 x 300 mm

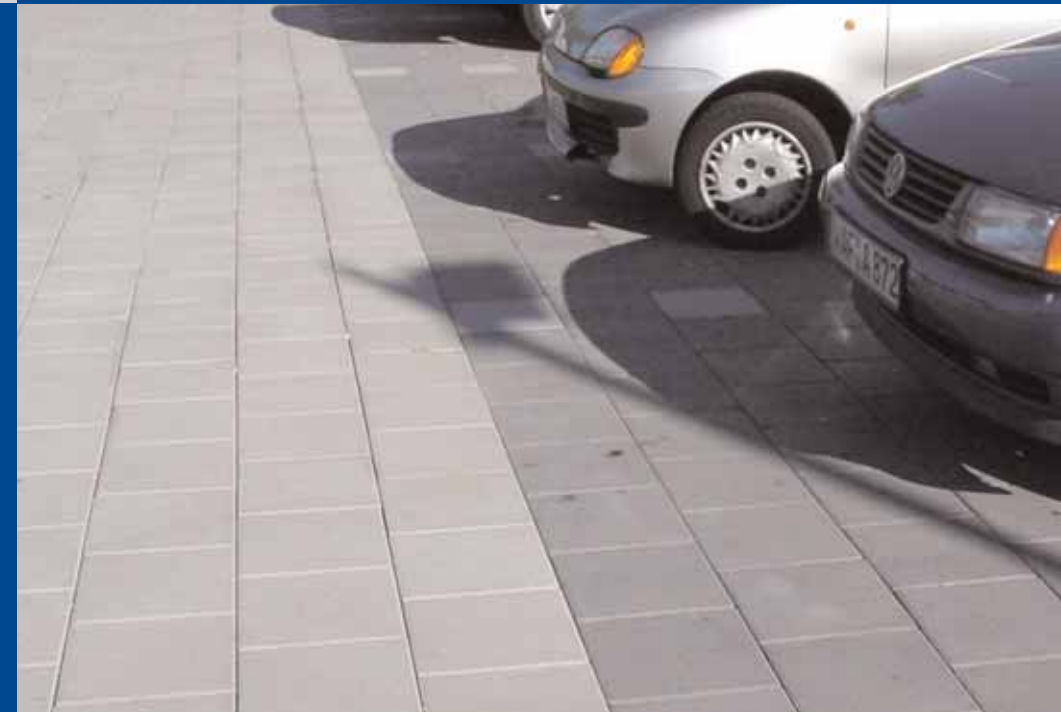
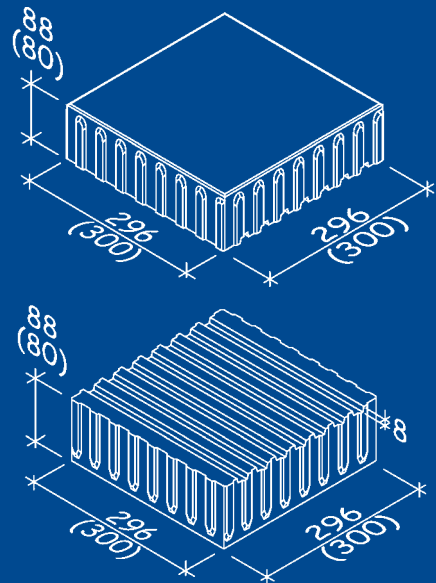

VS 5™ is a trademark of SF Concrete Technology Inc. U.S. Patent Application 10/490 710

Available at:



ANCHORAGE SAND and GRAVEL CO., INC.
 1040 O'Malley Road • Anchorage, AK 99515 • Toll-free: (888) 349-3133 • Phone: (907) 349-3333
 Fax: (907) 344-2844 • www.anchsand.com



The ingenious interlocking paving stone system

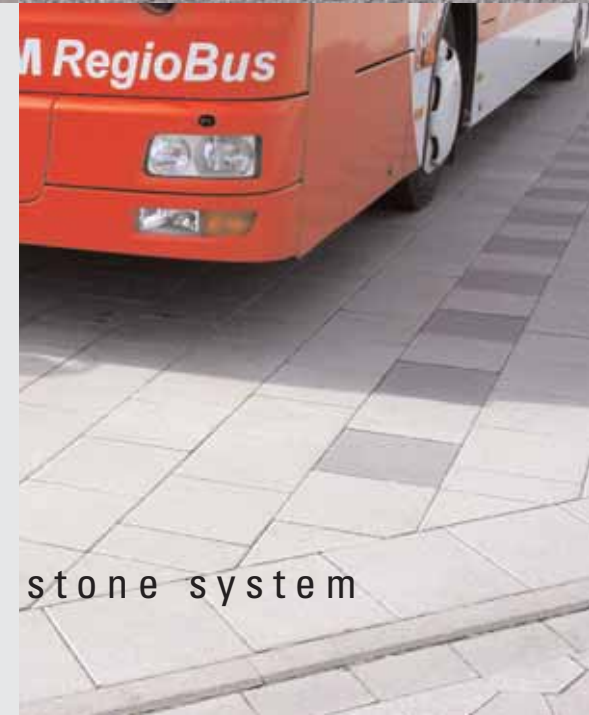

The five-sided shift resistance on all stone side and bottom surfaces results in an extremely stable pavement that protects against horizontal and vertical movements. This unique patented groove system, provides improved stability and interlocking capabilities that outperforms every other system.

Extremely narrow joints along with various colors and finishes make VS 5™ a very attractive surface.

VS 5™ offers technically advanced shift resistance – for the ultimate in pavement stability with superior good looks.

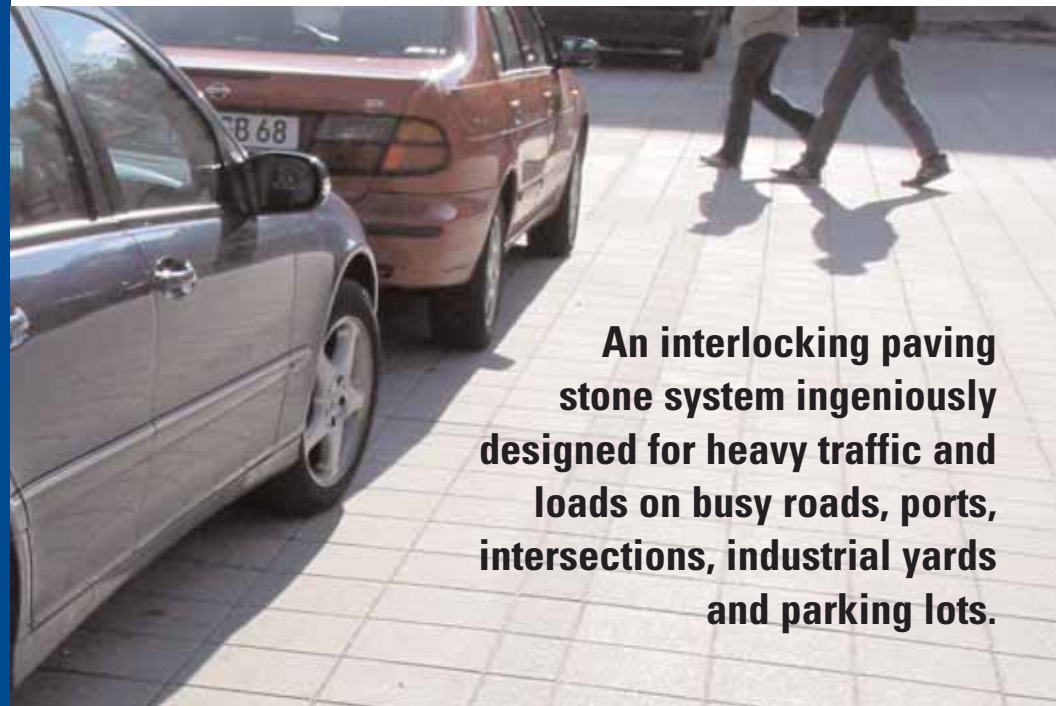

An interlocking paving stone system ingeniously designed for heavy traffic and loads on busy roads, ports, intersections, industrial yards and parking lots.

Engineers at the German company SF-Kooperation GmbH invented this product. Scientists at Ruhr University in Bochum, Germany, were mandated to conduct exhaustive research into interlocking groove applications in current construction processes and reached the following conclusions:

- The geometrical configuration of grooves around the paving stone transfers vertical and horizontal loads to adjacent paving stones and improves resistance to lateral shifting. VS 5™ paving stones can support loads without breaking.
- Grooves on the underside lock the paving stone into the bed and reduce horizontal shifting.
- Positioning the grooves in the direction of traffic improves efficiency.

Test results

Professor Klaus Krass of the Institute for Road Building and Railway Construction, Ruhr University Bochum in Germany conducted a series of tests on VS 5™ paving stones.

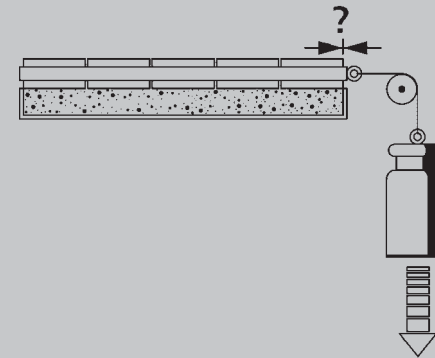

Shear-resistance test to determine friction coefficient

Tests show that VS 5™ paving stones with underside grooves possess a friction coefficient 54 % higher than concrete paving stones of same size without grooves.

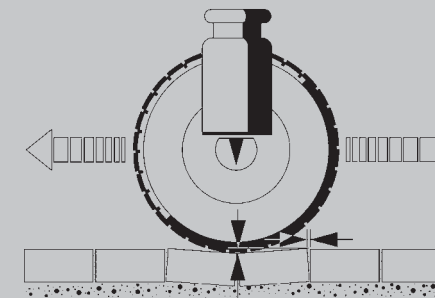

Wheel crossing tests with 40 kN single wheel load

Test results show that horizontal/longitudinal displacement was less than 1 mm after 30,000 crossings and was subsequently stable. During the last 4,500 crossings, brakes were applied at every tenth cross-over to simulate real road situations.

Results prove that vertical shifting is greatly reduced due to the geometrical configuration of the groove design around the paving stones.

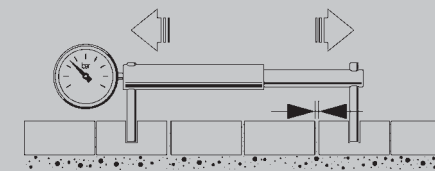

Spread test

Tests prove that horizontal shifting is greatly reduced compared to paving stones without underside grooves.



These narrow joints provide a perfect surface for pedestrians and a smooth ride for wheelchair users.

Extremely narrow joints trap jointing material between paving stones and therefore resist erosion and downward drifting.



VS 5™ paving stones with grooves on all four sides and underneath for enhanced, multi-directional interlock.

These grooves are specially designed for maximum stability.

