



## GREENSTREAK RETROFIT WATERSTOPS (JOINING NEW STRUCTURES TO EXISTING STRUCTURES)

GREENSTREAK offers several solutions for retrofit applications. Joints with movement potential can be addressed with one of GREENSTREAK's PVC Retrofit systems. **Hydrotite**, a strip applied hydrophilic waterstop, should be considered for applications where limited joint movement is expected. **Hydrotite** can also be considered for moving joint applications on a limited basis. Please consult Greenstreak for details.

### PVC RETROFIT SYSTEMS

PVC Retrofit systems are designed for applications requiring a seal between an existing structure and new construction. These systems can be used as an alternative to saw cutting and epoxy grouting in a conventional waterstop or the use of mastic type waterstops. The centerbulb design of the waterstop in conjunction with the elasticity of the PVC material allows for movement in the newly created joint.

Retrofit systems consist of a specially designed "Tee-shaped" PVC waterstop profile, pre-drilled stainless steel batten bars and stainless steel anchor bolts. Standard length for the PVC profile and batten bars is 10 feet, with batten bars pre-drilled with holes on 6-inch centers. Profiles are available in 6-inch and 9-inch base widths, suitable for concrete sections 6 inches thick and above. Batten bars and anchor bolts are sized according to the PVC profile selected.

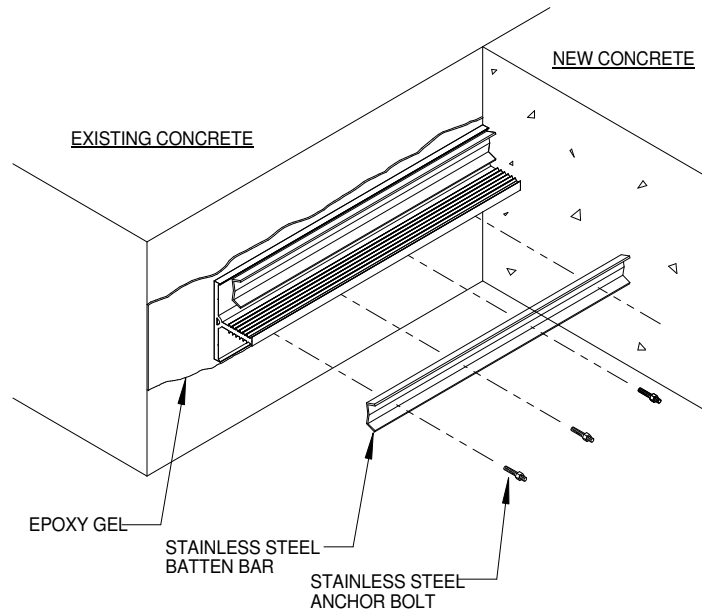

### INSTALLATION:

The existing concrete surface should be cleaned by sand blasting or grinding the surface to assure a solid, clean surface to bond the retrofit waterstop. Apply a bed of GREENSTREAK's 7300 Epoxy, approximately 1/8 inch thick and slightly wider than the waterstop base, to the concrete surface. Place the retrofit waterstop in place prior to the curing of the epoxy, securing the waterstop with the stainless steel batten bars and anchor bolts (powder actuated headed fasteners such as Hilti, Ramset, etc. may also be used). Fasten one side at a time, making sure the retrofit profile is positioned to eliminate any air pockets or voids between the waterstop and existing concrete.

Butt splicing should be accomplished by thermally fusing the free ends together prior to attachment to the wall. Thermostatically controlled, Teflon coated heating irons are available for this purpose. Factory fabrications should be used for transitions and changes of direction.

**HYDROTITE:**

Hydrotite is a state-of-the-art hydrophilic waterstop with unmatched durability and water sealing capacity. Comprised of non-bentonite, modified chloroprene rubber, Hydrotite expands up to eight times its original volume when exposed to water. This expansion creates an effective compression seal within joints of limited movement. Hydrotite profiles CJ-0725-3K and CJ-1020-2K are the profiles of choice in retrofit applications involving slab-to-slab, wall to slab or wall-to-wall joint conditions. These profiles as well as the DSS-0420 should be considered for pipe penetration applications.

**INSTALLATION:**

Hydrotite should be installed on smooth even surfaces to ensure good bonding. Position Hydrotite to ensure a minimum of two inches of concrete cover. Apply Greenstreak's Hydrotite Rubber Contact Adhesive to both the concrete surface and the Hydrotite profile. Once the adhesive becomes tacky to the touch, align the Hydrotite profile and press firmly into position. Careful positioning is a must as repositioning after contact will be difficult. Concrete nails, in conjunction with adhesives, may be used for vertical or overhead applications.

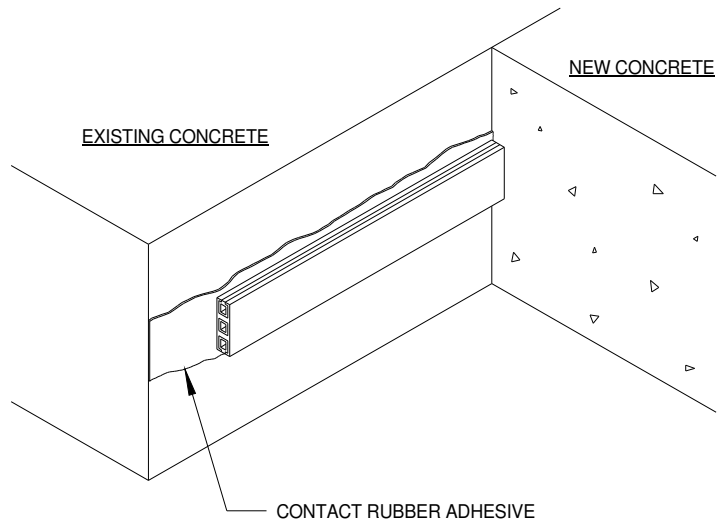

Hydrotite profiles should be spliced by cutting the ends square (or mitered for corners) with a sharp knife or shears. Bond the prepared ends together with a cyanacrylate (super glue) adhesive. LEAKMASTER, a hydrophilic caulk, can be used to further protect the splice area.

**Pipe Penetrations:**

Hydrotite is ideal for pipe penetrations, both on new construction as well as retrofit applications. Retrofit applications, where oversize cutouts are made, require the installation of two strips of Hydrotite. Install one strip around the outside diameter of the cutout, securing with adhesive and concrete fasteners as needed. Apply a second strip directly around the pipe. Slightly stretch the profile and bond the free ends together with cyanacrylate adhesive. Fill the annulus with a non-shrink epoxy grout. On new construction where concrete will be cast directly around the pipe, apply a single strip of Hydrotite around the pipe in a similar manner. Hydrotite CJ profiles can be used on larger diameter pipes (>18") while DSS-0420 will conform better to smaller diameters.

3400 Tree Court Industrial Blvd.  
 St. Louis, MO 63122  
 Phone (636) 225-9400 or (800) 325-9504  
 Fax (636) 225-2049 or (800) 551-5145  
 Greenstreak.com • E-mail info@greenstreak.com



GREENSTREAK GROUP, INC.  
 A Family of Construction Companies