

(A) 48" x 30" H (ID) WAVE PLANTER
SCALE: $\frac{1}{2}" = 1'$

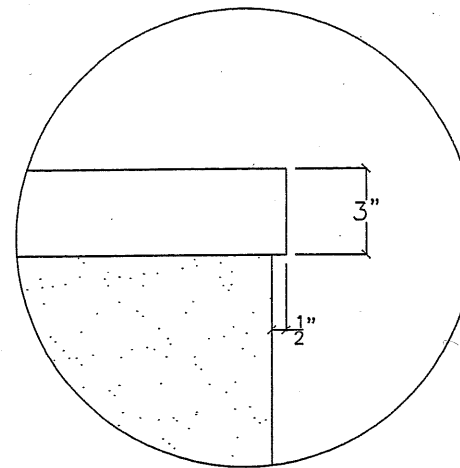

(C) PLANTER CORNER PLAN
SCALE: NTS

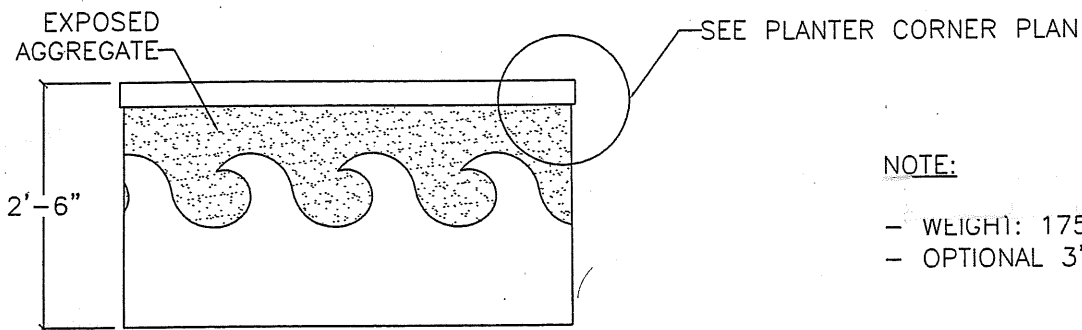

(B) PLANTER SIDE PLAN
SCALE: $\frac{1}{2}" = 1'$

NOTE:

- WEIGHT: 1750 LBS.
- OPTIONAL 3" BOTTOM W/ DRAIN HOLE

Scale:	AS SHOWN	Sheet 1	of 1
Date			
Designed	Aaron Chan	Drawing No.	
Drawn	Aaron Chan	05/16	
Checked			
Approved			

ROUND WAVE PLANTER

48" x 30" H (I.D.)

PRECAST CONCRETE
 11360 LANG STREET
 ANCHORAGE, AK 99515
 Ph. 907-344-6449 Fax: 907-349-2213